

TOLERANCE & MACHINE NOTES UNLESS OTHERWISE SPECIFIED		NAME	DATE
DIMENSIONS ARE IN INCHES @ 68.72 °		TM	7/1/07
TOLERANCES:		CHECKED	
TWO PLACE DECIMAL	±0.010	ENG APPR	
THREE PLACE DECIMAL	±0.005	MFG APPR	
FOUR PLACE DECIMAL	±0.0005		
MAXIMUM MACHINED SURFACE	0.0005		
ANGULAR: ±0.1°		COMMENTS	
CHAMFER ALL EDGES: 0.03 x 45°			
FILLET RADIUS: 0.015			
MATERIAL			
HEAT TREATMENT			
FINISH			
DO NOT SCALE DRAWING			

PTI Plasma Technics Inc.

TITLE: Small Plasma Block Assembly

SIZE: D DWG. NO: 78260 REV: 2

SCALE: 1:2 WEIGHT: SHEET 1 OF 2

REV.	CHANGES	DATE	ENG.
2	ADDED SHEET 2, ADDITIONAL MOUNTING CONFIGURATION	11/18/2008	TM
1	CAPTURED DESIGN CHANGES, UPDATED MOUNTING PATTERN	11/18/2008	TM
0	INITIAL RELEASE	11/18/2008	TM

PROPRIETARY AND CONFIDENTIAL
THE INFORMATION CONTAINED IN THIS DRAWING IS THE SOLE PROPERTY OF PLASMA TECHNICS INC. ANY REPRODUCTION IN PART OR AS A WHOLE WITHOUT THE WRITTEN PERMISSION OF PLASMA TECHNICS INC. IS PROHIBITED.

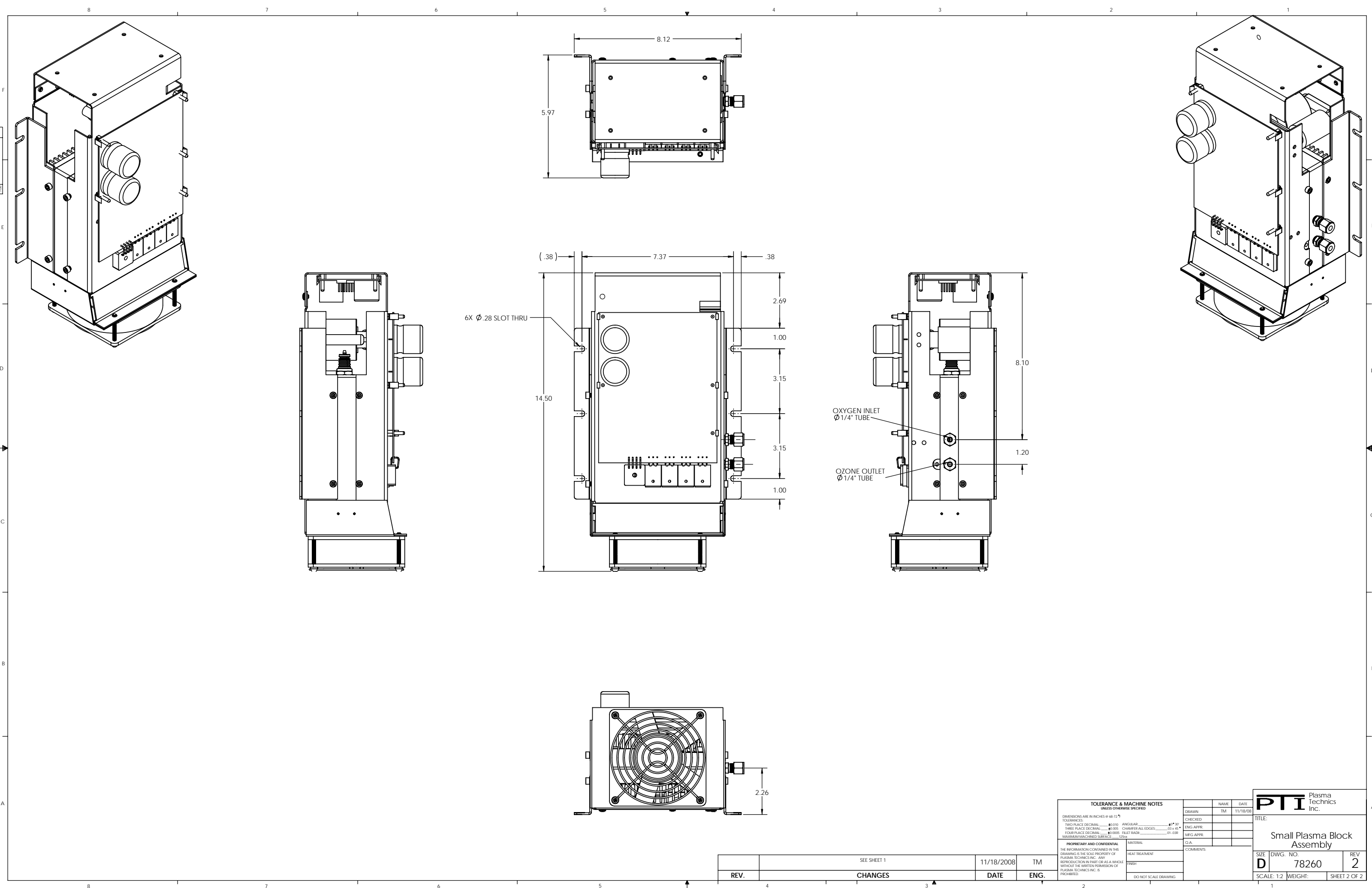

D
78260
2

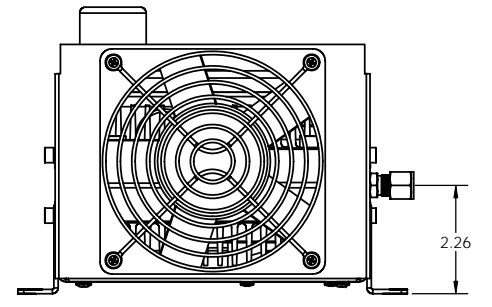
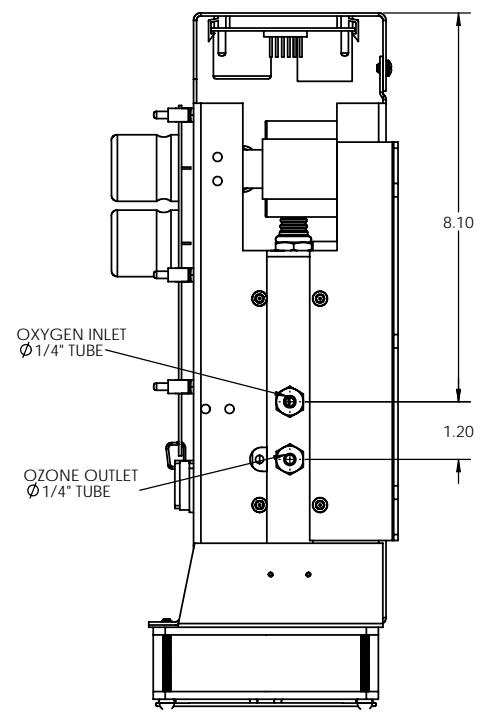
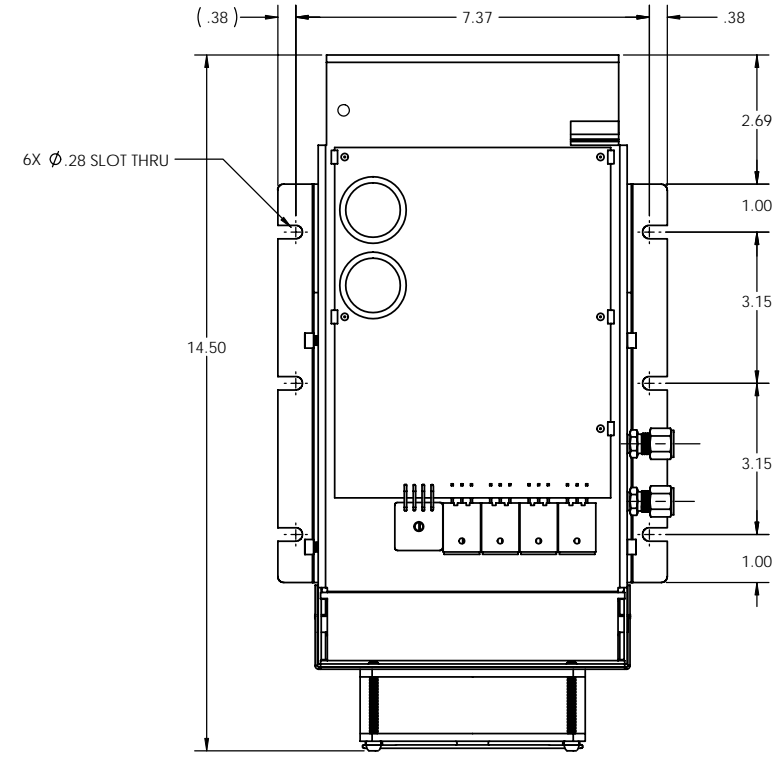
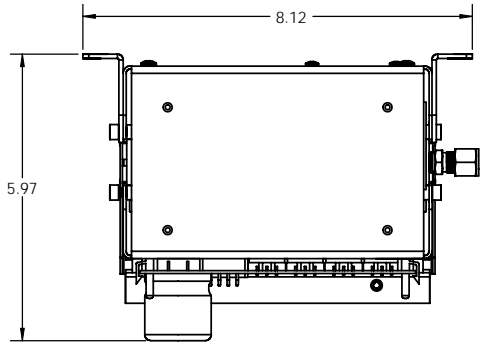

TOLERANCE & MACHINE NOTES UNLESS OTHERWISE SPECIFIED		NAME	DATE
DIMENSIONS ARE IN INCHES @ 68-72 °		TM	11/18/08
TOLERANCES:		CHECKED	
TWO PLACE DECIMAL	±0.010	ENG APPR	
THREE PLACE DECIMAL	±0.005	MFG APPR	
FOUR PLACE DECIMAL	±0.0005		
MAXIMUM MACHINED SURFACE	0.004		
ANGULAR: ±0.5°		COMMENTS	
CHAMFER ALL EDGES: 0.03 x 45°			
FILLET RADIUS: 0.015			
DO NOT SCALE DRAWING			

PTI Plasma Technics Inc.	
TITLE: Small Plasma Block Assembly	
SIZE D	DWG. NO. 78260
SCALE: 1:2	REV 2
WEIGHT:	SHEET 2 OF 2

REV.	CHANGES	DATE	ENG.
	SEE SHEET 1	11/18/2008	TM